

Model
LINEMISS™

- Convection oven
- Electric
- 3 trays 460x330
- Drop-down door opening
- Control knob

DESCRIPTION

Combi oven with humidity, analogical control and 304 stainless steel cooking chamber. Time, temperature, steam percentage and 1 fan speed function. Ideal for all cooking processes of fresh and frozen bakery products. The AIR.Plus technology guarantees perfect cooking uniformity on all baking trays.



STANDARD COOKING FEATURES

Manual cooking

- **Temperature:** 80 °C – 260 °C
- Convection and humidity cooking starting from 80 °C

STANDARD TECHNICAL FEATURES

- Cooking chamber in high-resistance AISI 304 stainless steel with rounded edges
- Double glass
- Cooking chamber lighting through LED lights embedded in the door
- Baking chamber with chrome-plated steel rack rails
- 1-speed fan system and high-performance circular resistance

ADVANCED AND AUTOMATIC COOKING FEATURES

Unox Intensive Cooking

- **DRY.Plus:** extracts humidity from the cooking chamber
- **STEAM.Plus:** creates instant humidity starting from 48 °C
- **AIR.Plus:** guarantees perfect cooking uniformity on all baking trays

XFT113

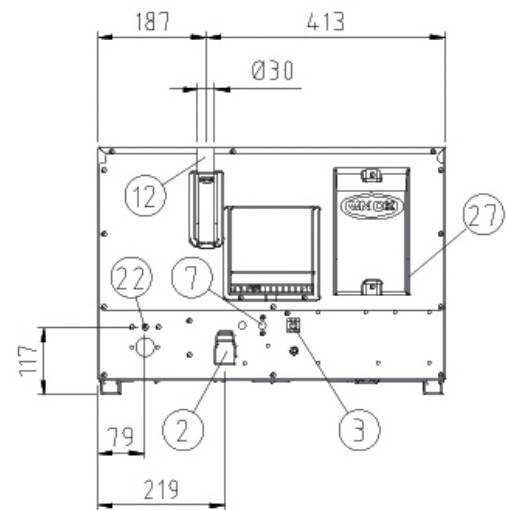
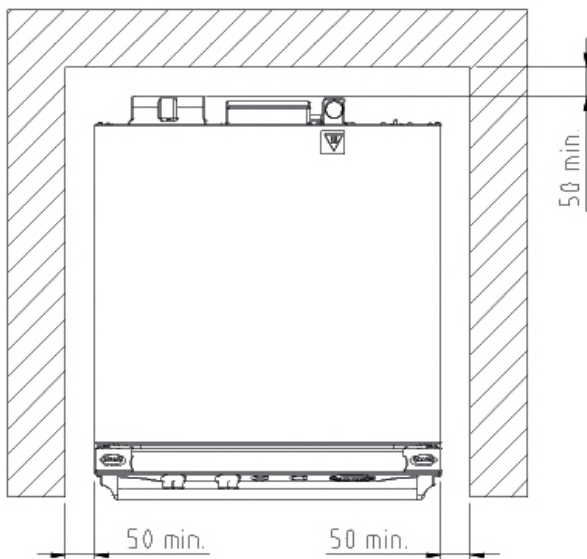
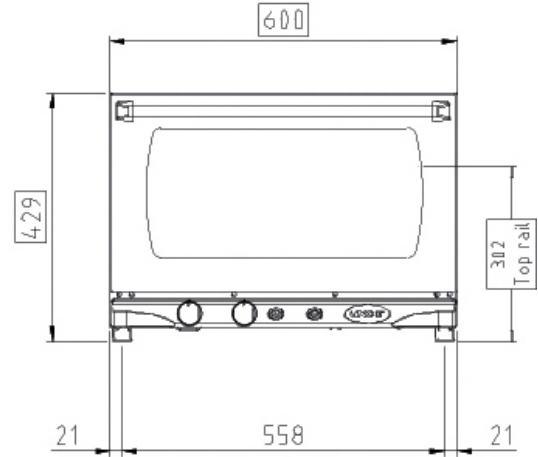
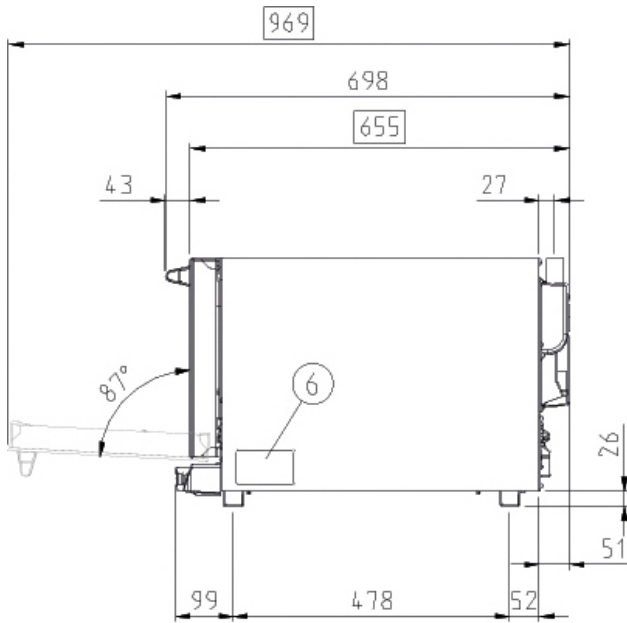

DIMENSIONS AND WEIGHT

Width	600 mm
Depth	655 mm
Height	429 mm
Net Weight	25 kg
Pan spacing	75 mm

CONNECTION POSITIONS

2	Terminal board power supply	12	Hot fumes exhaust chimney
3	Unipotential terminal	22	Water pump inlet
6	Technical data plate	27	Cooling air outlet
7	Safety thermostat		

POWER AND GAS SUPPLY

STANDARD

Voltage	220-240 V
Phase	~1PH+PE
Frequency	50 / 60 Hz
Total power	3 kW
Maximum Amp Draw	13 A
Required breaker size	16 A
Power cable requirement	H07RN-F 3G 3G
Cord diameter	10 mm
Plug	Schuko

ACCESSORIES

- **LIEVOX:** equipped with capable sensors to control and intervene automatically on the leavening process
- **Stand:** the multifunctional support ideal for storing trays safely and place your oven at the perfect height to work
- **Baking Essentials:** special trays
- **SPRAY&Rinse:** Practical spray detergent to manually clean all kinds of oven. Degreases and removes all kind of dirt
- **PURE:** the filter reduces the carbonate hardness in water, thus avoiding scale deposits inside the oven cooking chamber

INSTALLATION REQUIREMENTS

Installations must comply with all local electrical systems, particularly as for minimum wire gauge required for field connection, hydraulic and ventilation supply. Exhaust and fume analysis must be performed in case of gas ovens.

Register to access data and product specifications
infonet.unox.com

